

# CYTOPRO<sup>®</sup>

## CYTOCENTRIFUGE

# applications manual



Model 7622

**CYTOPRO<sup>®</sup>**

**CYTOCENTRIFUGE**

Model 7622

**Applications Manual**

57-2003-01B

REF

©2013 ELITechGroup Inc. All rights reserved. Printed in the United States of America. No part of this publication may be reproduced, transmitted, transcribed, stored in a retrieval system, or translated into any language (human or computer) in any form, or by any means whatsoever, without the prior express written permission of ELITechGroup Inc.

Wescor, Aerospray and Cytopro are trademarks of ELITechGroup Inc.

Other trade names used in this manual are trademarks of their respective owners, used here for information only.

ELITechGroup Inc. makes no express or implied warranty regarding this manual, its quality, performance, or appropriate use regarding any type of specific procedure. Elitech Group may modify this manual without notice and without implying any obligation or liability on the part of the company.

Manufactured in the United States of America by:



**ELITechGroup Inc.**  
370 West 1700 South  
Logan, Utah 84321-8212 USA



# Table of Contents

## Section 1

### Introduction

1.1 Cytopro Cytocentrifuge Overview .....	5
Using this Manual .....	5
Functional Description .....	6
Key Features .....	6
Intended Use .....	7
<i>Table 1: Cytopro Specifications</i> .....	8
<i>Table 2: Cytopro Rotor Specifications</i> .....	8
<i>Table 3: Sample Treatment Options</i> .....	9
<i>Table 4: Explanation of Symbols</i> .....	10
<i>Figure 1: The Cytopro Cytocentrifuge</i> .....	11
<i>Figure 2: Instrument Rear Panel</i> .....	11
The Cytopro Rotor .....	12
Sample Chamber Holder .....	12
<i>Figure 3: The Cytopro Rotor and Lid</i> .....	12
<i>Figure 4: Front Panel and Touchscreen</i> .....	13
Single Sample Chamber .....	13
Tunnel Port .....	13
Sample Port .....	13
Chamber Pressure Ring .....	13
<i>Figure 5: Single Chamber Assembly</i> .....	14
Dual Sample Chambers .....	14
Dual Chamber Wells .....	14
<i>Figure 6: Dual Sample Chamber</i> .....	15
Cytopro Magnum® Sample Chambers .....	15
Sample Well .....	15
Chamber Sealing Gasket .....	15
Fluid Absorption Chambers .....	15
<i>Figure 7: Cytopro Magnum Chamber</i> .....	16
Cytopro Absorption Pads .....	16
<i>Figure 8: Cytopad® Absorption Pads</i> .....	16
Chamber Frame .....	17
<i>Figure 9: Chamber Frame</i> .....	17
Microscope Slides .....	17
<i>Figure 10: Microscope Slides</i> .....	17
Barcode Reader .....	18
<i>Figure 11: Barcode Reader</i> .....	18
1.2 Touchscreen and User Interface .....	19
Table 5: Front Panel/Main Screen Function Keys .....	19
Table 6: System Setup Keys .....	20
1.3 Instrument Setup .....	22
Unpacking and Installing the Instrument .....	22
Connecting Power .....	22

## Section 2

### Controlling and Customizing Cytocentrifuge Functions

2.1 System Setup Menu .....	23
Accessing the System Setup Menu .....	23
Creating a Cytocentrifuge Program .....	23
Editing a Cytocentrifuge Program .....	24
Changing the Program Name .....	24
Deleting a Cytocentrifuge Program .....	24
Administrator and User Accounts .....	24
Creating an Administrator Account .....	24
Creating User Accounts .....	25

## Table of Contents

### Section 2

#### Controlling and Customizing Cytocentrifuge Functions (continued)

<i>Managing User Access</i> .....	25
<i>User Login/Logout</i> .....	26
Changing User Language .....	26
Setting the Date and Time .....	26
System Log.....	27
<i>Accessing Logs</i> .....	27
<i>Exporting Logs</i> .....	27
Controlling Beeper Alerts .....	27
Slide and Specimen Tracking .....	28
<i>Enable Cyto Slide Tracking</i> .....	28
<i>Enable Manual Entry</i> .....	28
Restoring Software Defaults.....	29
2.2 Recording Specimen and Slide Information .....	30
Scanning Slides with the Barcode Reader.....	30
Manually Entering Specimen Information.....	31
2.3 The Help Menu.....	32

### Section 3

#### Operating the Cytocentrifuge

3.1 Running A Cytocentrifuge Cycle .....	33
Suggested Cytocentrifugation Protocol .....	33
Balancing the Rotor .....	33
Preparing and Loading Slides.....	33
Loading Chambers into the Rotor.....	34
<i>Single or Dual Chambers</i> .....	34
<i>Cytopro Magnum Chambers</i> .....	34
Loading Samples.....	35
Performing a Cytocentrifuge Cycle.....	35
Unloading the Rotor .....	36
Separating Chambers from Cytopads.....	37
Attaching Cytopads to Chambers .....	38

### Section 4

#### Preventive Maintenance and Safety

4.1 Routine and Preventive Maintenance.....	39
Figure 9: Lubricating the Carousel Locking Pin .....	39
Replacing Fuses .....	40
4.2 Cleaning and Decontamination Procedures .....	41
Cleaning the Case Exterior and Lid .....	42
Cleaning the Instrument Bowl and Inner Lid .....	42
Chemically Disinfecting the Rotor .....	42
Autoclaving the Rotor.....	43
Chemically Disinfecting Single or Dual Chambers.....	44
Autoclaving Single or Dual Chambers.....	44
4.3 Shipping or Disposing of the Instrument or Rotor.....	45
Shipping the Instrument or Rotor.....	45
<i>Hazard Free Certification Form</i> .....	45
Disposing of the Instrument or Rotor.....	45

### Section 5

#### Solving Problems

5.1 Troubleshooting .....	46
Table 7: General Troubleshooting and Diagnosis .....	46
5.2 Calibrating the Touchscreen.....	48

### Section 6

#### Customer Service

Customer Service .....	49
------------------------	----

<b>Appendix A: Critical Reagent Components</b> .....	50
--	----

<b>Appendix B: Accessories and Supplies</b> .....	51
---	----

## 1.1 Cytopro Cytocentrifuge Overview

### Using this Manual

This manual provides instructions to install, operate, and maintain the Cytopro Cytocentrifuge.

The manual is an important part of the product. Read it carefully and completely before setup and first use of the instrument.

If additional accident prevention and environmental protection requirements exist in the country of operation, this manual must be supplemented by appropriate instructions to ensure compliance.

#### Safety Regulations

This instrument has been built and tested to safety regulations for electrical control, regulating, and laboratory devices. In order to maintain this condition and ensure safe operation, the operator must observe all the instructions and warnings contained in this manual. For current information about applicable standards, please refer to the CE Declaration of Conformity included with the documents shipped with this device.

**NOTE:** *This equipment* complies with the emission and immunity requirements described in the IEC 61326 series.

#### Understanding Warnings

This manual uses three levels of warnings to alert you to important information as shown in the following examples.

#### WARNING!

**A Warning alerts to the possibility of personal injury, death, or other serious adverse reactions stemming from the use or misuse of this device or its components.**

#### CAUTION:

A Caution alerts to possible problems with the device associated with its use or misuse. Such problems include device malfunction, failure, damage, damage to the sample, or damage to other property. Where applicable, a Caution may include precautions to be taken to avoid the hazard.

**NOTE:** *A Note reinforces or supplies additional information about a topic.*

#### Specific Warnings

Pay particular attention to the following safety precautions. If these safety precautions are ignored, injury or damage to the instrument may occur. Each individual precaution is important.

#### WARNING!

**The Cytopro rotor lid, rotor gaskets and related components are intended to be part of a biosafety system as specified in international and national biosafety guidelines. They cannot be relied on as the only means of safeguarding workers and the environment when handling pathogenic microorganisms.**

## SECTION 1 INTRODUCTION

### **1.1 Cytopro Cytocentrifuge Overview**

**WARNING!**

**If power is lost during cytocentrifugation, the lid remains locked until power is restored. Do not attempt to open the lid while power is off.**

**WARNING!**

**Electrical shock hazard: Do not open this instrument or attempt internal repairs. Refer servicing to qualified service personnel. Contact Elitech Group Biomedical Systems service.**

**CAUTION:**

Use only spare parts supplied or specified by Elitech Group. Using non-approved parts may affect the performance and safety features of the instrument. Using this equipment in a manner not specified by Elitech Group may impair the protection provided by the equipment. If in doubt, contact your Elitech Group representative.

#### **Functional Description**

Cytopro is a complete, general-purpose cytocentrifuge system for depositing cells onto microscope slides. Cytopro incorporates microprocessor control and user programmability to provide great versatility.

The Cytopro rotor uses centrifugal force and three unique patented chamber designs to sediment cells onto the slide. With the single or dual chambers, suspension fluid is simultaneously absorbed into the Cytopad absorption pad as cells contact the microscope slide. With the Cytopro Magnum large capacity chamber, the suspension fluid is removed by an absorbent foam at the end of the run.

The Cytopro system includes the instrument cabinet, rotor, standard volume chamber assemblies (which includes the single or dual chambers, chamber caps, Cytopads, and frames), and the Cytopro Magnum chambers. The Cytopro system is used with standard or custom microscope slides.

The Cytopro rotor allows rapid sedimentation of specimen cells onto microscope slides for staining or other purposes. Up to eight disposable/reusable sample chamber assemblies with absorbent pads and glass microscope slides can be loaded into the rotor.

The Cytopro rotor reduces cell loss during collection and prevents accidental damage to the collected specimen. The rotor is sealed to control aerosol release during cytocentrifugation.

#### **Key Features**

- Single, Dual, and Cytopro Magnum chambers
- Reusable or disposable, chambers (single and dual)
- Capacity of eight slides and chambers
- User-programmable speed, acceleration rate, and time
- Autoclavable rotor

SECTION 1  
INTRODUCTION

***1.1 Cytopro Cyto centrifuge Overview***

**Intended Use**

The Cytopro Cyto centrifuge is an in vitro diagnostic medical device for fixing biological cell suspensions on glass microscope slides for cytological examination. The Cytopro can be used with the following cell suspensions:

- Bronchoalveolar liquid (BAL)
- Cerebrospinal fluid (CSF)
- Urine
- Synovial fluid
- And many more



## SECTION 1 INTRODUCTION

### 1.1 Cytopro Cyto centrifuge Overview

**Table 1: Cytopro Specifications**

Category	Characteristics
Electrical Requirements	100 to 240 VAC @ 50 to 60 Hz
Power Consumption	200 Watts maximum
Fuses	2.0 Amp time-lag (Type T) (5 x 20 mm) (2 required). Manufactured by Littlefuse (Part No. 218002) or Bussman (part No. GDC-2A)
Rotor Speed Range	100 to 2000 rpm ( $\pm 5\%$ )
Acceleration Rate	Low, Medium, High ( $\pm 5\%$ )
Cycle Time	1 to 99 min ( $\pm 5\%$ )
Ambient Temperature	
Operating	15 to 30 °C
Storage	0 to 40 °C
Relative Humidity	$\leq 80\%$ non-condensing
Safety Features	Lid Interlock: Lid must be closed to begin a cycle, and remains locked down while rotor is spinning
Display	7 in. WVGA (800 x 480 pixels) TFT
Touch Screen Controls	Menu-driven icons
Weight	10.1 kg (22.2lb)
Dimensions	
Width	57 cm (22 in.)
Height (lid closed)	25 cm (10 in.)
Depth	54 cm (21 in.)
Height (lid open)	58 cm (23 in.)
Altitude	$\leq 2000$ m ( $\leq 6562$ ft.)

**Table 2: Cytopro Rotor Specifications**

Category	Characteristics
Sample Well Capacity*	Single: 0.5 mL max Dual: 2 x 0.3 mL Cytopro Magnum: 6 mL
Cell Deposit Area	Single = 38.5 mm <sup>2</sup> (7 mm diameter) Dual = 77 mm <sup>2</sup> (2 x 7 mm diameter) Cytopro Magnum = 315 mm <sup>2</sup>
Rotor Capacity	Up to 8 slides and Cytopro chambers
Rotor Dimensions (Diameter x Height, including lid)	22.6 x 6.2 cm (8.9 x 2.4 inches)
Rotor Weight (including lid)	1.1 kg (2.5 lb)

\*Do not overfill cyto centrifuge chambers. See Section 3.1 or the Cytopro Methods Manual for detailed instructions and warnings.

# SECTION 1 INTRODUCTION

## 1.1 Cytopro Cyto centrifuge Overview

**Table 3: Sample Treatment Options**

The chart below suggests procedures for various fluids. Refer to the Methods Manual for more detailed information. Methods currently used in other cyto centrifuges will often work in the Cytopro, if the maximum volume of fluid and the run time is adjusted appropriately (see chart).

	Sample Prep	Cytopad Type	Sample Vol (mL)*	Loading Position	Prewet (mL)	In Situ Fix (mL)	Speed (rpm)	Time (min)**	Acceleration
<b>Hematology</b>									
CSF	e, f	Tan	0.2	Well	0-0.1	N/A	1000	3-5	High
Urine	a, d, e, f	Tan	0.2	Well	0-0.1	N/A	1000	3-5	High
Synovial	c, d, e, f	White	0.2	Well	0-0.1	N/A	1000	3-5	High
Sputum	c, e	White	0.2	Well	0-0.1	N/A	1000	3-5	High
Aspirates	a, c, d, e, f	Tan/White	0.2	Well	0-0.1	N/A	1000	3-5	High
Washes	a, d, e, f	Tan/White	0.2	Well	0-0.1	N/A	1000	3-5	High
<b>Gram</b>									
CSF	e, f	Tan	0.2	Well	0-0.1	N/A	1000	3-5	High
Urine	a, d, e, f	Tan	0.2	Well	0-0.1	N/A	1000	3-5	High
Synovial	c, d, e, f	White	0.2	Well	0-0.1	N/A	1000	3-5	High
Sputum	c, e, f	White	0.2	Well	0-0.1	N/A	1000	3-5	High
Aspirates	a, c, d, e, f	Tan/White	0.2	Well	0-0.1	N/A	1000	3-5	High
Washes	a, d, e, f	Tan/White	0.2	Well	0-0.1	N/A	1000	3-5	High
<b>Cytology</b>									
CSF	b, e, f, g	Tan	0.2	Well	0-0.1	Optional	1000	3-5	High
Urine	a, d, e, f, g	Tan	0.2	Well	0-0.1	Optional	1000	3-5	High
Synovial	b, c, d, e, f, g	Tan	0.2	Well	0-0.1	Optional	1000	3-5	High
Aspirates	a, b, c, d, e, f, g	Tan/White	0.2	Well	0-0.1	Optional	1000	3-5	High
Washes	a, b, d, e, f, g	Tan/White	0.2	Well	0-0.1	Optional	1000	3-5	High
Pre-Fixed	d, e, f, g	Tan	0.2	Well	0-0.1	Optional	1000	3-5	High
Cytopro Magnum	a, b, c, d, e, f, g	N/A	2-6	Well	N/A	N/A	2000	3-10	High

**LEGEND**

Sample Preparation

- a. Treat bloody samples.
  - 1. Collect in anticoagulant.
  - 2. Lyse red cells.
- b. If processing will be delayed, preserve fragile cells.
- c. Treat viscous samples if necessary.
- d. Remove precipitates or debris when necessary.
- e. Adjust cell count.
  - Large (epithelial) 8,000 - 12,000 per 0.2 mL sample
  - Medium (urothelial) 16,000 - 24,000 per 0.2 mL sample
  - Small (leukocytes) 50,000 - 125,000 per 0.2 mL sample
  - 1. Concentrate low cellularity samples by precentrifugation.
  - 2. Dilute high cellularity samples with balanced saline plus 2 to 4 percent bovine serum albumin (BSA).
- f. Adjust cell environment where necessary.
- g. Use treated slides to increase cell adhesion.

**Cytopad:**† Thin samples = slow (tan).  
Thick samples = fast (white).

**Sample:** 0.1 to 0.3 mL optimal. Samples less than 0.1 mL yield increased volume cell loss (0.5 mL max -total fluid-single chamber). 0.6 mL max total fluid for dual sample chamber (2 x 0.3 mL).

**Cytopro Magnum:** 2 to 6 mL optimal. Dilute smaller samples with diluent before cyto centrifugation to obtain at least 2 mL.

**Prewetting:**† Load up to 200 µL balanced saline in tunnel, (sample in well).

**In Situ Fix:**† Load up to 200 µL of sample in tunnel, 50 to 100 µL of saccomanno type fixative in sample well.

**Speed:** High speed for small cells, low for large and/or fragile cells.

**Time:** Samples with debris, viscosity or high cellularity will require extended run times.

\* 1 drop of distilled water equals 20 to 40 µL depending on pipette used. Other fluids may fall outside this range.

















\*\* For samples in balanced saline, increase time up to 2x for BSA samples and native body fluids.

† Standard volume chambers only.

SECTION 1  
INTRODUCTION

**1.1 Cytopro Cytocentrifuge Overview**

**Table 4: Explanation of Symbols**

	Biological Hazards (Biological Risks)
	Alternating Current (AC)
	Power ON
	Power OFF
	Caution, Consult Accompanying Documents (Attention, see instructions for use)
	Biological Hazard Symbol
	Manufacturer's Representative in Europe
	Manufactured by
	Waste Electrical and Electronic Equipment (WEEE)
	CE Mark, Product meets the essential requirements designated in Annex I of the In Vitro Device Directive (IVDD) 98/79/EC
	In Vitro Diagnostic Medical Device
	Consult Instructions for Use
	Environment Friendly Use Period
	Catalog Number (Model Number)
	General Symbol for Recovery, Recyclable
	Batch Code

**1.1 Cytopro Cyto centrifuge Overview**

**Figure 1: The Cytopro Cyto centrifuge**

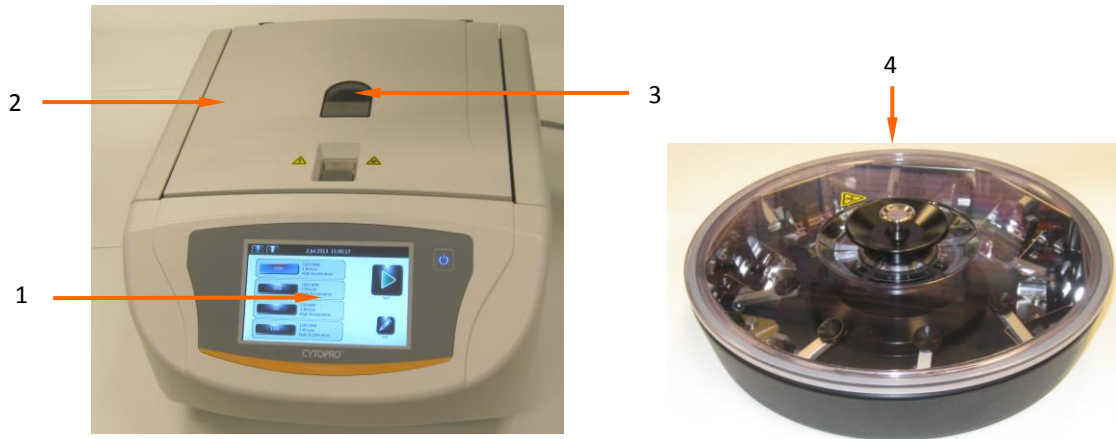

- 1 – Interactive Touchscreen/Display
- 2 – Lid
- 3 – Rotor Rotation Observation Port
- 4 – Cytopro Rotor

**Figure 2: Instrument Rear Panel**

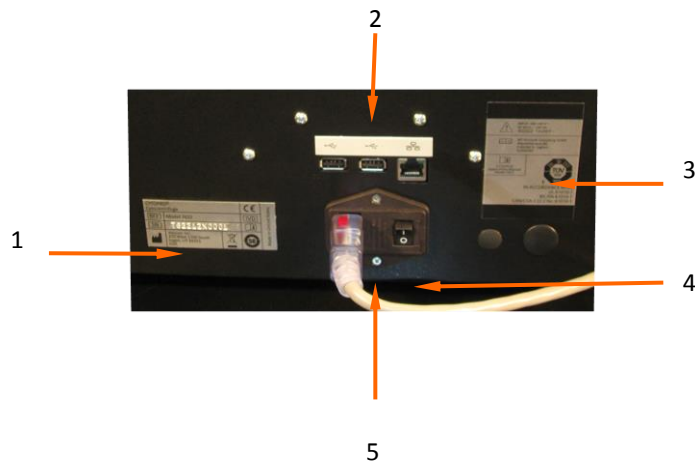

- 1 – Model and Serial Number Label
- 2 – USB and Ethernet Connections
- 3 – Rear Panel Label
- 4 – Power Switch
- 5 – Power Entry Module/Fuse Door

## SECTION 1 INTRODUCTION

### 1.1 *Cytopro Cyto centrifuge Overview*

#### The Cytopro Rotor

The Cytopro rotor holds up to eight sample chamber assemblies, and microscope slides. The rotor operates on the drive hub of the instrument. The self-sealing, autoclavable rotor is easy to load in a biological safety cabinet. The lid seals airtight to contain biological hazards. The low-profile rotor allows easy access during loading. While in the rotor, slide labels are always visible for easy sample identification.

#### Sample Chamber Holder

Each sample chamber holder uses spring compression to maintain the seal between chamber and slide. This helps control the rate of absorption in the standard chambers.

Depress the release lever to load and unload chamber assemblies and slides. This lever action cleanly retracts the chamber away from the slide; slides are easily removed without smearing the cells.

**Figure 3: The Cytopro Rotor and Lid**

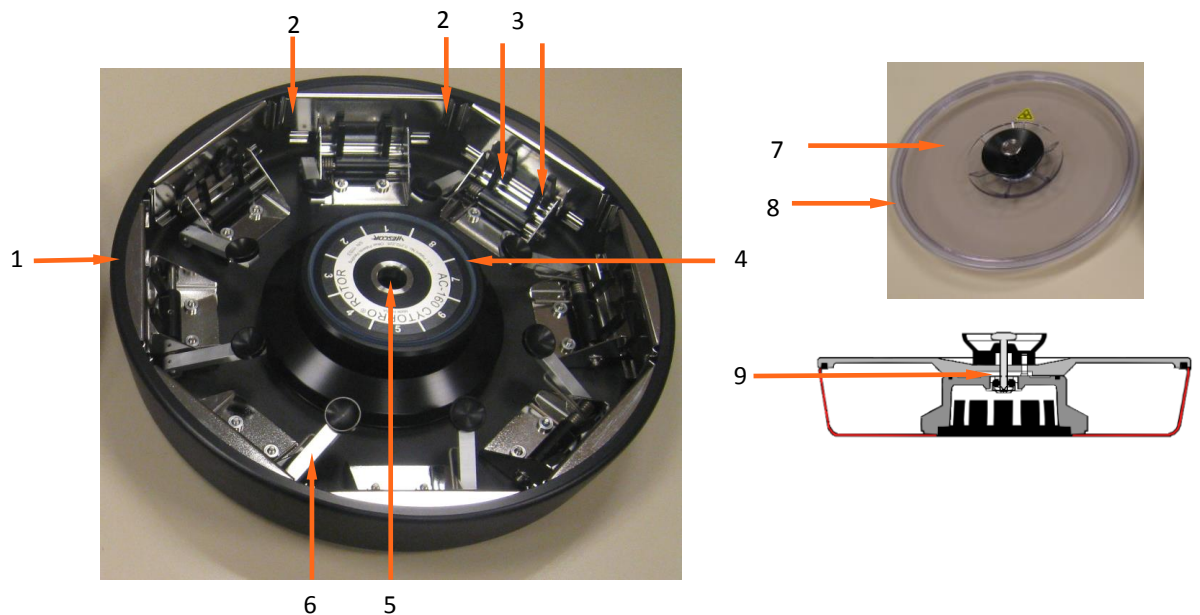

- 1 – Cytopro Cyto centrifuge Rotor
- 2 – Slide Bracket (2 in each position)
- 3 – Chamber Lever Fingers (2 in each position)
- 4 – Hub Seal
- 5 – Locking Pin Receptacle
- 6 – Chamber/Slide Release Lever
- 7 – Rotor Lid with Locking Lid Latch
- 8 – Bowl Seal
- 9 – Cytopro Rotor with Locking Lid

## 1.1 Cytopro Cytocentrifuge Overview

**Figure 4: Front Panel and Touchscreen**

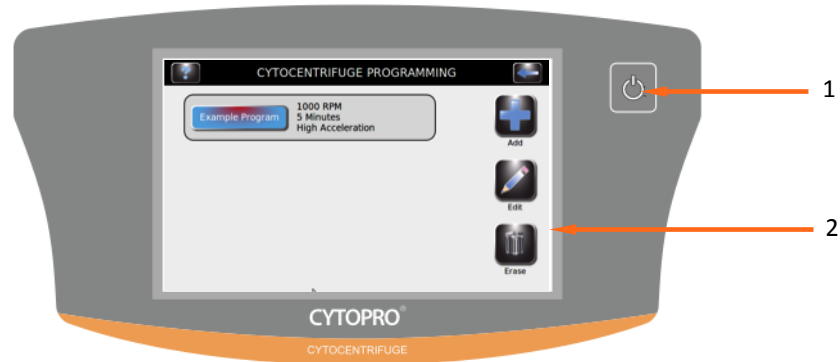

- 1 – Standby/Ready Button
- 2 – Touchscreen

The front panel features an interactive touchscreen display. Refer to Touchscreen and User Interface (Section 1.2, Table 5) for more information.

### Single Sample Chamber

The reusable single chamber features a dual-port sample loading port system that places a 38.5 mm<sup>2</sup> (7 mm diameter) spot on the microscope slide.

#### Tunnel Port

The tunnel port allows up to 200 µL of fluid to be placed directly into the chamber tunnel. This allows flexibility in sample treatment, including in situ fixation and pad prewetting.

#### Sample Port

Load samples into the sample port for most applications. The sample well holds up to 0.5 mL of fluid. Use a pipette to load sample fluid through the open ports or through air vents in the chamber cap. See Section 3.1 for more information.

#### Chamber Pressure Ring

The raised ring at the end of the chamber tunnel seals the Cytoslide against the glass slide to restrict fluid flow during cytocentrifugation.

## SECTION 1 INTRODUCTION

### 1.1 Cytopro Cyto centrifuge Overview

**Figure 5: Single Chamber Assembly**

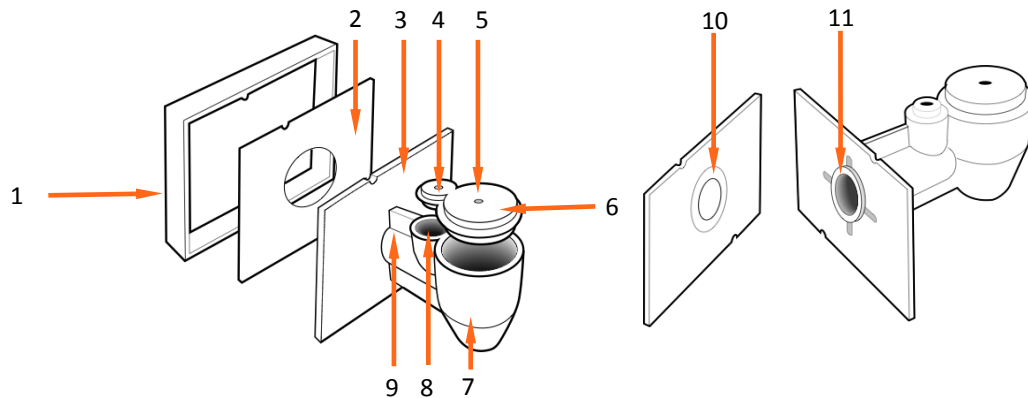

- 1 – Chamber Frame
- 2 – Cytopad
- 3 – Chamber Base
- 4 – Tunnel Port Cap Vent
- 5 – Sample Well Cap Vent
- 6 – Cap
- 7 – Sample Well
- 8 – Tunnel Port
- 9 – Chamber Tunnel
- 10 – Flow Control Ring
- 11 – Chamber Pressure Ring

#### **Dual Sample Chambers**

Dual chambers are designed to operate the same way as single chambers. The reusable dual sample chambers allow you to place two 38.5 mm<sup>2</sup> (7 mm diameter each) spots of specimen on the same microscope slide.

##### **Dual Chamber Wells**

Each sample well holds up to 0.3 mL of fluid (a total of 0.6 mL per slide). Use a pipette to load sample fluid through the open ports or through air vents in the chamber cap. See Section 3.1 for more information.

## 1.1 Cytopro Cytocentrifuge Overview

**Figure 6: Dual Sample Chamber**

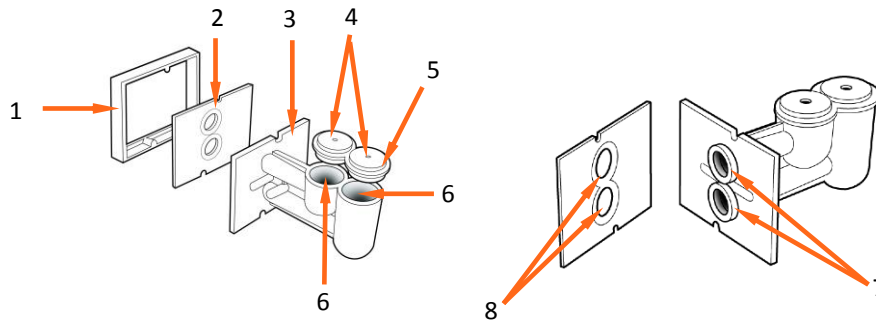

- 1 – Chamber Frame
- 2 – Cytopad
- 3 – Chamber Base
- 4 – Cap Vents
- 5 – Cap
- 6 – Sample Wells
- 7 – Chamber Pressure Rings
- 8 – Flow Control Rings

### Cytopro Magnum® Sample Chambers

The disposable, non-reusable Cytopro Magnum sample chamber allows you to place a rectangular 315 mm<sup>2</sup> spot of specimen on a single microscope slide.

#### Sample Well

The sample well holds up to 6.0 mL of fluid. The sample can be either poured into the sample well or pipetted through the open port in the sample well cap. Make sure the chamber cap is properly secured prior to running the sample. Failure to do so may allow fluid to leak into the rotor.

#### Chamber Sealing Gasket

The gasket at the end of the sedimentation chamber seals the Cytopro Magnum against the glass slide to prevent fluid from leaking during cytocentrifugation.

#### Fluid Absorption Chambers

The two fluid absorption chambers are filled with an absorbent media that absorbs the residual sample fluid after the cells are removed through cytocentrifugation.

**NOTE:** *The absorbent media may turn yellow with age and light exposure. This color change does not affect the absorption properties of the media and the chambers can still be used with confidence.*



SECTION 1  
INTRODUCTION

**1.1 Cytopro Cyto centrifuge Overview**

**Figure 7: Cytopro Magnum Chamber**

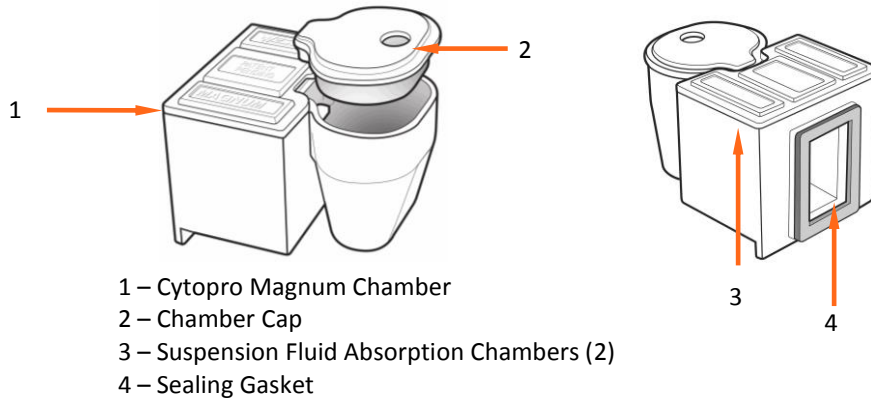

**Cytopad® Absorption Pads**

Cytopads (standard chambers only) absorb suspension fluid and allow sample cells to sediment onto the microscope slide. Cytopads feature compressed flow-control rings for controlled absorption of suspension fluids.

Cytopads are available in two absorption rates. The slow (tan) pad is for rapidly absorbed fluids of low viscosity, low cellularity, or low turbidity. Use the fast (white) pad for more viscous cell suspensions.

**NOTE:** Tan pads may vary in color from lot to lot and even from pad to pad. These color differences do not change the performance of the pad. The tan color is used to differentiate these pads from the white pads.

Cytopads are held securely between the chamber and the chamber frame for dependable performance.

**Figure 8: Cytopad Absorption Pads**

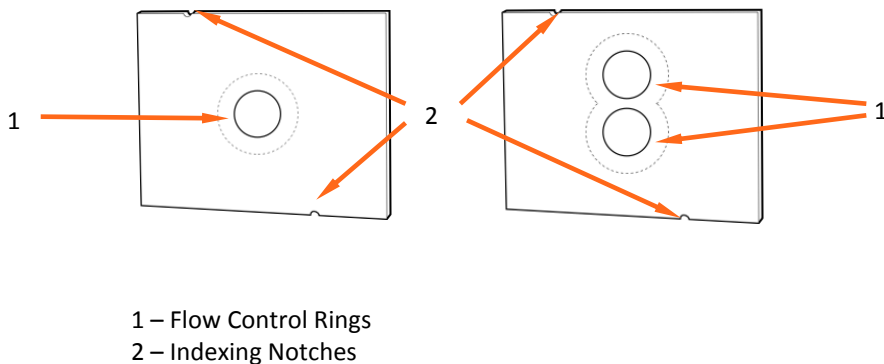

## 1.1 Cytopro Cyto centrifuge Overview

### Chamber Frame

Chamber frames accept either single or dual replacement pads and have a cutaway to prevent cells from being smeared as the chamber assembly is removed. Indexing pins on the frame ensure correct Cytopad alignment. Cytopads come pre-attached to chambers or in boxes of 100 for attaching to reused chambers.

**Figure 9: Chamber Frame**

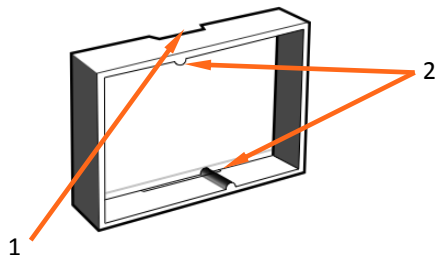

- 1 – Clearance Cutaway
- 2 – Indexing Pins

### Microscope Slides

Use standard (25 x 75 mm) glass microscope slides. For cytology specimens, use coated slides to reduce cell loss during wet fixation and staining.

Elitech Group offers specially designed target slides for the Cytopro system. These slides are available in uncoated (single SS-117; dual SS-217; Cytopro Magnum SS-232) and Poly-L-Lysine coated (single SS-118; dual SS-218; Cytopro Magnum SS-233).

**Figure 10: Microscope Slides**

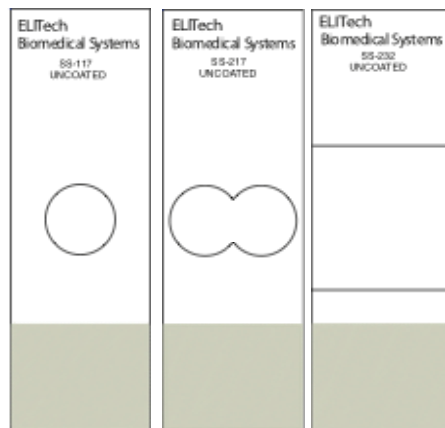

SECTION 1  
INTRODUCTION

**1.1 Cytopro Cyto centrifuge Overview**

**Barcode Reader**

An optional barcode reader is available for the Cytopro Cyto centrifuge.





**Figure 11: Barcode Reader**



**1.2 Touchscreen and User Interface**

Users control all instrument functions from the interactive touchscreen display.





**Table 5: Front Panel/Main Screen Function Keys**

Button	Name	Description
	Standby/Ready	With instrument power ON: Blue = Ready Amber = Standby  Pressing Standby places instrument into standby mode  The Standby/Ready button also accesses the touchscreen calibration function. Refer to System Setup Menu, (Section 2.1)
	System Information	Shows the system information, including serial number and software version. Allows access to the System Setup features. Refer to System Setup Menu, (Section 2.1).
	Help	Opens the software Help file
	Programs	Allows users to select or edit programs
	Start/Load Slides	Begins a cycle. The Start button is inactive until a program is created. Refer to Creating a Cytocentrifuge Program (Section 2.1)  With Slide Tracking enabled, opens the Scan and Load Slides and Specimen menu, (Section 2.1)







SECTION 1  
INTRODUCTION

**1.2 Touchscreen and User Interface**

**Table 5: Front Panel/Main Screen Function Keys (continued)**

Button	Name	Description
	Back	Returns to the previous menu
	Stop	Aborts any operation
	OK	Indicates completion of current task
	System Setup	Allows users to modify the software settings. See System Setup menu, (Section 2.1)

**Table 6: System Setup Keys**

Button	Name	Description
	Cyto Programs	Allows users to create, edit, and delete cyto centrifuge programs
	Users	Allows users to create and change user accounts
	Tracking	Enables slide tracking using the bar code reader or by manual entry
	Language	Allows users to change the display language
	System Log	Allows users to control logging functions
	Network Settings	Allows users to change network settings
	Beeper	Allows users to change audible alerts

**1.2 Touchscreen and User Interface**

**Table 6: System Setup Keys (continued)**

Button	Name	Description
	Set Date/Time	Allows users to set the date and time
	Restore Defaults	Restore programming to default settings
	Unselected	Shows an unselected option
	Selected	Shows a selected or enabled option
	Login	Enters Login sequence for authorized users.
	Logout	Logs authorized users out. Users must log in again to use the stainer.
	Save	Saves the entered or selected information.
	Add	Enters programming mode for creating cytoentrifuge programs. Also allows the system administrator to authorize new users. Allows manual entry of slide or specimen information.
	Delete/Erase/Remove	Deletes or erases the selected item.
	Edit/Change User	Allows editing of an existing cytoentrifuge program. Allows manual entry of slide or specimen information. Also allows system administrator to edit user information.

## SECTION 1 INTRODUCTION

### 1.3 Instrument Setup

#### Unpacking and Installing the Instrument

**CAUTION:**

Contact Elitech Group before installing the instrument if you observe any damage to the packaging or equipment.

- 1 Unpack and inspect the instrument.
- 2 Check that the contents of the boxes match the packing lists for instrument and accessories.
- 3 Open the instrument lid and remove the cardboard tube that protects the hub.

**NOTE:** Keep the box and packaging material to repack the instrument if you intend to ship it to the manufacturer for service.

- 4 Place the instrument on a flat surface, free from dust and vibration and away from direct sunlight.

**NOTE:** Position the instrument with the rear panel at least 30 cm (12 in.) from obstructions or hazardous materials.

#### Connecting Power

- 1 Make sure the power switch is **OFF** (O).
- 2 Plug the power cord into the power connector on the rear panel of the instrument.

**NOTE:** Use a surge protector to isolate the instrument from spikes and surges.

- 3 Plug the power cord into a properly rated AC electrical outlet.
- 4 Turn the power switch **ON** (I). After a brief delay the Main menu will appear.

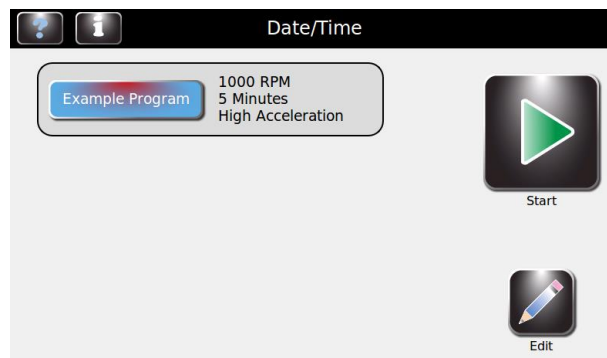

## SECTION 2 CONTROLLING AND CUSTOMIZING CYTOCENTRIFUGE FUNCTIONS

### ***2.1 System Setup Menu***

Many software settings can be controlled from the System Setup menu.

#### **Accessing the System Setup Menu**



- 1 Press **System Information**.



- 2 Press **System Setup**.



#### **Creating a Cytocentrifuge Program**



- 1 From the System Setup menu, press **Cyto Programs**.



- 2 Press **Add**.

- 3 Enter a program name in the Program Name field.

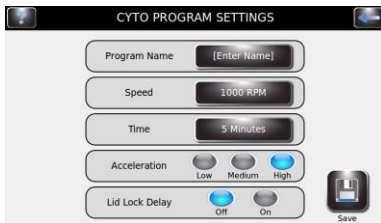

- 4 Enter the program speed setting in rpm.

- 5 Enter the program time.

- 6 Select the acceleration speed (LOW, MED, HIGH).

- 7 Choose ON or OFF for the lid lock delay.

- 8 Press **Save**.



## SECTION 2 CONTROLLING AND CUSTOMIZING CYTOCENTRIFUGE FUNCTIONS

### 2.1 System Setup Menu

#### Editing a Cytocentrifuge Program

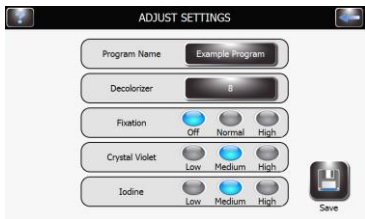

- 1 From System Setup, press **Cyto Programs**.
- 2 Select the program to be modified.
- 3 Press **Edit**.
- 4 Adjust the settings as desired.
- 5 Press **Save**.



#### Changing the Program Name:

- 1 From Cyto Program Settings menu, select **Program Name**.
- 2 Press **Edit**.
- 3 Enter the program name on the keypad.
- 4 Press **Enter**.

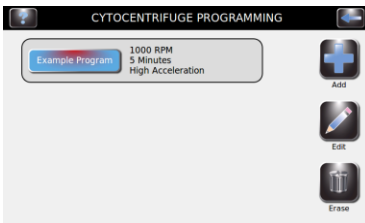

#### Deleting a Cytocentrifuge Program

- 1 From the System Information menu, press **System Setup**.
- 3 Press **Cyto Programs**.
- 4 Select the program to be deleted.
- 5 Select **Erase**.

### Administrator and User Accounts

You can create one Administrator account and multiple (up to 50) user accounts. The Administrator controls access to the system by adding and editing user accounts. Users cannot edit System Settings unless permitted by the Administrator.



#### Creating an Administrator Account

- 1 From System Setup, select **Users**.
- 2 Select **Lock System Setup Access**.
- 3 Enter a password for the Administrator account (at least 4 characters).
- 4 Re-enter the password to confirm.

## SECTION 2 CONTROLLING AND CUSTOMIZING CYTOCENTRIFUGE FUNCTIONS

### ***2.1 System Setup Menu***

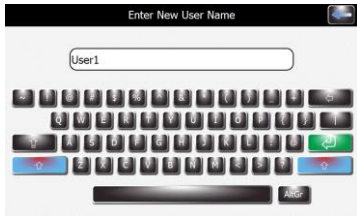

#### **Creating User Accounts**

- 1 Select **System Setup**.
- 2 Enter the Administrator password.
- 3 Press **Users**.
- 4 Select **Enable Global Login**.
- 5 Select **Add User**.
- 6 Enter a user name.
- 7 Press **Enter**.
- 8 Enter a numeric passcode (at least 4 numbers) for the user account.
- 9 Press **Enter**.
- 10 Re-enter the same passcode to confirm.
- 11 Press **Enter**.

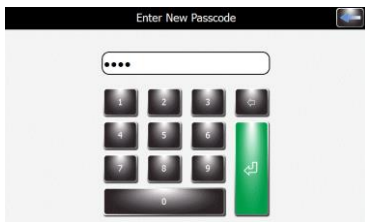

#### **Managing User Access**

On the Manage Users screen, the Administrator has several options to manage user access to the instrument.

- Enable Global Login allows users to log in to the instrument. Users will log out manually or automatically (with user-selectable time options). See User Login/Logout below.
- Enable Run Login requires the current user to enter a password to run a Cytocentrifuge cycle. Global Login must be enabled to use this option.
- User System Access enables complete control of the instrument, including changing the System Setup options. This option can be controlled on an individual user basis, if Global Login is enabled.

## SECTION 2 CONTROLLING AND CUSTOMIZING CYTOCENTRIFUGE FUNCTIONS

### 2.1 System Setup Menu

#### User Login/Logout

With System Access locked and Global Login enabled, users must log in to use the cytocentrifuge:



- 1 Select **User ID** and select **Logout Time After Idle For:** from the drop-down menu.



- 2 Press **Login**.

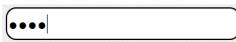

- 3 Enter the correct passcode for the selected user and press **Enter**.



- 4 The cytocentrifuge returns to the Main menu and is ready for programming and staining.

- 5 Once Login is complete, the Main screen appears. A Logout button and the user name appear at the top right of the screen.

#### Changing User Language



- 1 From System Setup, press **Language**.

- 2 Select the software language from the list on the left.



- 3 Select **OK**.

#### Setting the Date and Time



- 1 From System Setup, press **Set Date/Time**.

- 2 Choose **12** for a 12-hour clock or **24** for a 24-hour clock.

- 3 Use the up and down arrows to modify the time and date.



- 4 Press **Save**.

## SECTION 2 CONTROLLING AND CUSTOMIZING CYTOCENTRIFUGE FUNCTIONS

### 2.1 System Setup Menu

#### System Log

The instrument records all login, logout, cytocentrifuge cycles, setting changes, and specimen identification (if enabled).



#### Accessing Logs

- 1 From System Setup, press **System Log**.
- 2 Use navigation arrows to scroll through the log.



#### Exporting Logs

- 1 From System Setup, Press **System Log**.



- 2 Plug a Flash Drive into the right USB port.



- 3 Press **Export**.

**NOTE:** The log files are exported to the Flash Drive as a CSV file that can be opened in spreadsheet software programs.

#### Controlling Beeper Alerts



- 1 From System Setup, select **Beeper**.

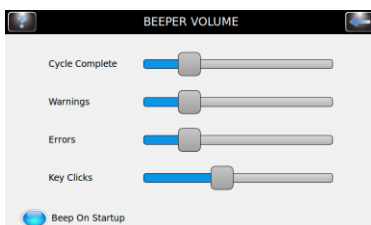

- 2 Use the sliders to modify the beeper volume for Cycle Complete, Warnings, Errors, or Key Clicks.

- 3 Select **Beep On Startup** to turn the audible startup alert ON or OFF.

## SECTION 2 CONTROLLING AND CUSTOMIZING CYTOCENTRIFUGE FUNCTIONS

### 2.1 System Setup Menu

#### Slide and Specimen Tracking

Under system default settings, the following options are disabled:

- Enable Cyto Slide Tracking
- Enable Manual Entry

#### Enable Cyto Slide Tracking

To activate Stain Slide Tracking, use the following steps:

- 1 From System Setup, Press **Tracking**.
- 2 Press **Enable Cyto Slide Tracking**.

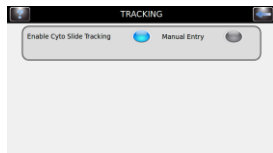

**NOTE:** Selecting *Enable Cyto Slide Tracking* changes the *Start* button on the *Main menu* to “*Load Slides*.”

- 3 Press **Back** twice to return to the main screen. Verify that the Start Button on the main screen reads “Load Slides.”
- 4 Press **Load Slides**. The Scan and Load Slides menu appears.
- 5 Scan or enter slide information.
  - a. If using the barcode reader, scan the specimen slides that contain barcodes. See *Scanning Slides with the Barcode Reader* in Section 2.2 for complete instructions.
  - b. If entering specimen information manually, see *Recording Specimen information* in Section 2.2.
- 6 See Section 3 for remaining steps for running a cytocentrifuge cycle.

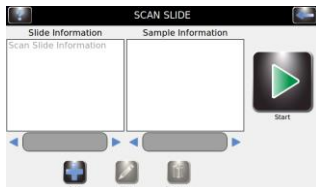

#### Enable Manual Entry

If selected, allows manual entry of slide information using the keypad (limited to 24 characters).

## SECTION 2 CONTROLLING AND CUSTOMIZING CYTOCENTRIFUGE FUNCTIONS

### ***2.1 System Setup Menu***

#### **Restoring Software Defaults**

- 1 From System Setup, select **Restore Defaults**.

**CAUTION:**

Restoring the system defaults will remove all personal settings.

- Restoring *System* Settings will delete all user names and passwords as well as all stain and cytocentrifuge programs.
- Restoring *Cytocentrifuge* Settings will delete all cytocentrifuge programs and restore the default program.

- 2 Select the settings you would like to restore to factory defaults: System Settings or Cytocentrifuge Settings.



- 3 Press **Restore**.



- 4 The display returns to the Main menu.

## SECTION 2 CONTROLLING AND CUSTOMIZING CYTOCENTRIFUGE FUNCTIONS

### 2.2 Recording Specimen and Slide Information

#### Scanning Slides with the Barcode Reader



- 1 From System Setup select **Tracking**.

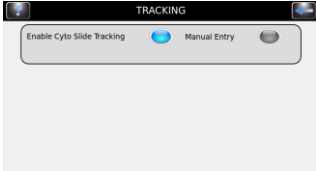

- 2 Select **Enable Cyto Slide Tracking**.

**NOTE:** Selecting *Enable Cyto Slide Tracking* changes the *Start* button on the Main menu to: “Load Slides.”



- 3 Press **Back** twice to return to the Main menu.



- 4 Press **Load Slides** on the Main menu. The Scan Slide menu will appear.



- 5 Scan the barcode of each slide and specimen (using the ID barcode accompanying the specimen) in the batch. Load the rotor according to instructions in Section 3.

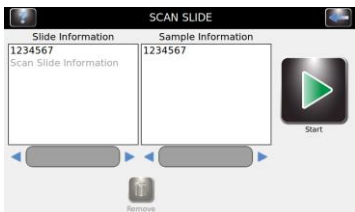

- 6 Verify that each barcode appears on the Scan and Load Slides menu.



- 7 When you have completed preparations, (Section 3) press **Start**.

## SECTION 2 CONTROLLING AND CUSTOMIZING CYTOCENTRIFUGE FUNCTIONS

### *2.2 Recording Specimen and Slide Information*

#### **Manually Entering Specimen Information**

With Cyto Slide Tracking and Manual Entry enabled in the Tracking menu:



- 1 Press **Load Slides** on the Main Menu.



- 2 Press **Add** to reveal the keypad.



- 3 Enter slide information (maximum of 24 characters) and/or specimen information (using the ID accompanying the specimen) and press **Return**.



- 4 To change or delete the entry, select the entry on the display and press **Edit** or **Remove**.

- 5 Load slides and run cytocentrifuge cycle as shown in Section 3.



## SECTION 2 CONTROLLING AND CUSTOMIZING CYTOCENTRIFUGE FUNCTIONS

### **2.3 The Help Menu**

The Help menu is a comprehensive onscreen help function that provides detailed information on the following subjects:

#### **Basic Operation**

- System Setup Help
- Setting Up Cyto Programs
- Setting Up Users
- Setting Instrument Language
- Setting the Date and Time
- Instrument Logging
- Setting Up Network Setting
- Setting Instrument Beeps
- Calibrating Touch Screen
- Restoring Instrument Defaults

#### **Cytocentrifuge Use**

##### **Setting Up Cyto Programs**

##### **Using Help**



1 Press **Help** to access the help function.

2 Select the desired topic.



3 Use the direction arrows to navigate.



4 Press **Exit Help** to return to the Main menu.

## SECTION 3 OPERATING THE CYTOCENTRIFUGE

### 3.1 Running a Cytocentrifuge Cycle

#### Suggested Cytocentrifugation Protocol

- If enabled, scan or enter cyto slide and/or specimen information.
- Prepare and load slides into the rotor.
- Load chambers into the rotor.
- Load samples into the chambers.
- Place loaded rotor onto the instrument hub and close the lid.
- Select or verify desired cytocentrifuge program.
- Perform a cytocentrifuge cycle.
- Remove rotor from the instrument.
- Check for complete absorption of suspension fluids.
- Remove chambers for cleaning or disposal.
- Remove slides for further processing.

#### Balancing the Rotor

The Cytopro rotor contains eight sample chamber stations. When preparing fewer than eight samples, balance the rotor by placing chambers and slides in opposing stations (using an empty chamber and slide if necessary). This prevents a rotor imbalance from interrupting the centrifuge process.

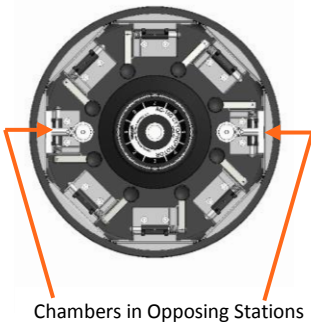

When using Cytopro Magnum chambers, the carousel must be balanced with another Cytopro Magnum chamber and slide that has approximately the same sample volume, for example: a 6 mL sample should be balanced with a sample of at least 5 to 6 mL. An empty Cytopro Magnum chamber and slide will not adequately balance the rotor.

**NOTE:** Property stickers or tags can also potentially imbalance the rotor. Institutional identification marks should be virtually weightless if placed on the rotor.

**NOTE:** A warning will sound during the cycle if the rotor is unbalanced.

#### Preparing and Loading Slides



- 1 Clean microscope slides provide maximum cell adherence. Use pre-cleaned, premium-grade slides.
- 2 For better cell adherence, pretreat slides or use custom pretreated slides.

**NOTE:** Even clean slides show improved cell adherence after pre-treating with chemical adherents such as Poly-L-Lysine or amino silane.

## SECTION 3 OPERATING THE CYTOCENTRIFUGE

### 3.1 Running a Cytocentrifuge Cycle

#### Preparing and Loading Slides (continued)



- 3 If Slide Tracking is enabled, press **Load Slides**.
  - If using the barcode reader (Section 2.2, Recording Specimen and Slide Information), scan each specimen slide and specimen barcode before loading it into the carousel. Slide tracking must be enabled from the System Setup menu. See Recording Specimen and Slide Information in Section 2.2.
  - If entering slide information manually, follow the instructions in Section 2.2.
- 4 Place each slide into a slide bracket with the labeled side facing into the rotor. Slides can be loaded without depressing release levers.

#### Loading Chambers into the Rotor



##### Single or Dual Chambers:

- 1 Make sure each slide is correctly loaded into a slide bracket with the labeled side facing into the rotor.
- 2 Use Table 3 in Section 1.1 to select a chamber with the desired type of Cytopad (fast = white, slow = tan).

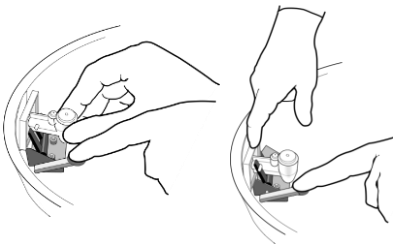

- 3 Depress the release lever and insert a chamber assembly.
- 4 Release the lever while gently pressing down on the top of the chamber frame to ensure the chamber is squarely seated.

##### Cytopro Magnum Chambers:

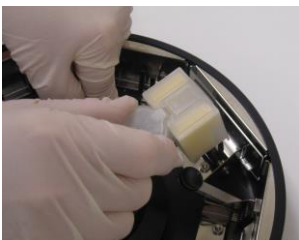

- 1 Make sure each slide is correctly loaded into a slide bracket with the labeled side facing into the rotor. Slides can be loaded without depressing release levers.
- 2 Depress the release lever and insert a Cytopro Magnum chamber over the prongs of the two chamber lever fingers.
- 3 To ensure the chamber is squarely seated, release the lever while gently pressing down on the top of the chamber.

## SECTION 3 OPERATING THE CYTOCENTRIFUGE

### 3.1 Running a Cytocentrifuge Cycle

#### Loading Samples

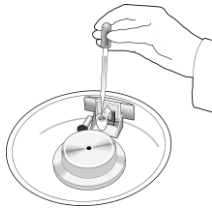

- 1 Load sample and prewetting fluids through cap vents, or directly into the ports before the cap is placed on the chamber. Use the chamber caps to minimize contamination and accidents. Chamber caps are mandatory for the Cytopro Magnum.

The vent holes in the standard volume chamber caps accept either glass Pasteur pipette tips or 200 microliter automatic pipette tips. Cytopro Magnum chamber caps accept up to 10 mL automatic pipette tips. Refer to Sample Treatment Options (Table 3 in Section 1) or the Cytopro Methods Manual (RP-451) for sample treatment considerations.

#### **WARNING!**

**Always load chambers in a biological safety hood, using appropriate hand and eye protection.**

#### **WARNING!**

**Do not exceed listed maximum sample volume: (0.5 mL for the single chamber, 0.3 mL in each well of the dual chamber, 0.6 mL total, or 6 mL for the Cytopro Magnum chamber).**

- 2 Place the lid on the rotor by lifting the locking pin as you place the center pin into the rotor lid receptacle. Press down on the locking pin until it locks.

**NOTE:** Locking and unlocking the lid is easier if you press down near the center of the lid with one hand while operating the locking pin with the other.

- 3 Carefully transfer the rotor to the instrument. Avoid bumping or tilting the rotor.

#### Performing a Cytocentrifuge Cycle

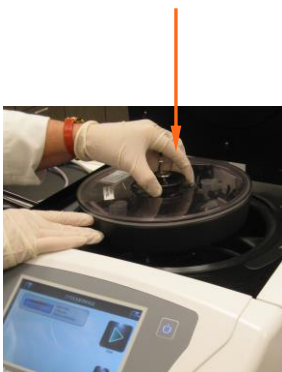

- 1 From the Main menu, select the desired cytocentrifuge program, or program the desired settings using the instructions in Section 2.1 (Creating a Cytocentrifuge Program).
  - If you have not enabled slide and specimen information entry, proceed to step 3.
  - If you have enabled slide and specimen information entry, press **Load Slides**.
  - Scan or enter the slide and sample information.
  - Load slides and specimens and replace the rotor lid as instructed in this section.
- 2 Insert rotor loaded with specimens and slides and close the instrument lid.
- 3 Press **Start**.



## SECTION 3 OPERATING THE CYTOCENTRIFUGE

### 3.1 Running a Cytocentrifuge Cycle

The display shows the progress of the program, and a signal tone (if enabled) indicates the end of the cycle.



**NOTE:** Use the emergency Stop button when required, for example, if there is abnormal vibration or noise. This will abort the cycle.

#### Unloading the Rotor

**NOTE:** When slides are removed from the rotor, cells rapidly begin to dry. Transporting exposed slides subjects them to air flow and greatly accelerates drying. Slides to be wet-fixed for Papanicolaou staining should be processed near the rotor or transported in the rotor to the treatment site. Fix slides as quickly as possible after removing from the rotor. In situ fixation will prevent these problems.

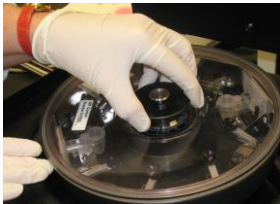

- 1 Open the instrument lid and transfer the rotor to a biological safety hood.
- 2 Remove the rotor lid by pressing with one hand on the center of the rotor lid while lifting the locking pin with the other hand.



#### CAUTION:

Never attempt to release the lid by holding the lid knob and shaking the rotor with the locking pin released. This can allow the rotor to drop and damage the microscope slides and rotor.



- 3 Check single or dual chambers for residual suspension fluid by looking for fluid in the chamber tunnel. If the fluid is not completely absorbed, rerun the sample. If fluid flow is stopped, try the following:
  - Grip the rotor as shown.
  - Press the upper right section of the chamber base with your right thumb while slightly pressing the release lever with your other hand.
  - Hold for a few seconds until residual fluid (observable in the chamber tunnel) is absorbed into the Cytopad.

#### CAUTION:

Removing fluid by these methods causes some cell loss. The remaining cells may not be completely flattened against the slide.

## SECTION 3 OPERATING THE CYTOCENTRIFUGE

### 3.1 Running a Cytocentrifuge Cycle

#### Unloading the Rotor (continued)

Cytopro Magnum chambers must remain in the rotor and in contact with the slide for 45 seconds after cytocentrifugation has stopped. This allows the fluid to be completely absorbed by the absorbent media. Use the lid unlock delay function to ensure the 45-second delay is completed before opening the lid. See Section 5.1 (Troubleshooting) or the Methods Manual (RP-451) for additional information.

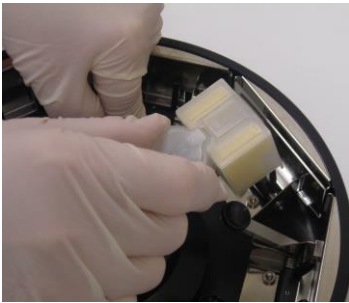

- 4 Completely depress the release lever and remove the chambers.
- 5 Discard used chambers and Cytopads in a biohazard container or according to local regulations and prudent laboratory practices.
- 6 Remove the slides. Quickly wet fix or air dry depending on desired staining to follow. (Wet fix for Papanicolaou, dry fix for hematology and Gram stains.)

**NOTE:** If you intend to reuse standard volume chambers, you must thoroughly clean and decontaminate them using the methods described in Section 4.2. Cytopro Magnum chambers must be discarded after use.

#### Separating Chambers from Cytopads

The following information applies only to the reusable standard volume chambers. Cytopro Magnum chambers are single use only and must be discarded after each use.

#### **WARNING!**

**This procedure requires safety protection for hands and eyes.**

Before cleaning, chambers must be separated from the used Cytopads, which are not reusable. To remove Cytopads:

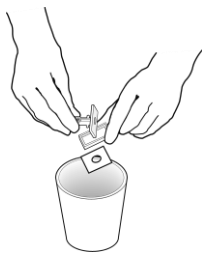

- 1 Remove the frame from the chamber.
- 2 Use the sample chamber base to push the used Cytopad out of the frame and into a biohazard container for disposal.
- 3 Place chambers and frames immediately into a detergent or disinfectant to prevent cells from drying onto chamber surfaces. Sterilize chambers according to instructions in Section 4.2.

## SECTION 3 OPERATING THE CYTOCENTRIFUGE

### ***3.1 Running a Cytocentrifuge Cycle***

#### **Attaching Cytopads to Chambers**

To reuse a chamber, attach a new Cytopad after the chamber is cleaned, disinfected, and thoroughly dried.

To assemble Cytopads with sample chambers:

- 1 Place a Cytopad inside a chamber frame, using the indexing pins for correct positioning.
- 2 Snap the frame over the chamber base. Be sure the sample chamber base is securely seated in the frame.

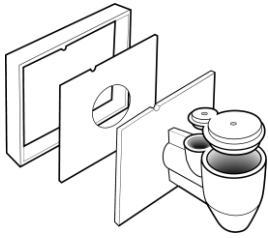

#### **WARNING!**

**Dispose of all used chambers or Cytopads according to local regulations and prudent laboratory practices.**

## SECTION 4

### PREVENTIVE MAINTENANCE AND SAFETY

#### ***4.1 Routine and Preventive Maintenance***

The Cytopro is designed to be simple to use and care for with few user-serviceable components. Maintenance is primarily keeping the instrument and rotor clean (see Section 4.2). Other preventive measures are listed below:

- **Check Seals**  
Hub and bowl seals must be inspected frequently for cracks or signs of deterioration. Replace seals yearly, or whenever they show any signs of wear.
  
- **Lubricate Lid Latch Mechanism**  
Treat the lid latch mechanism with the grease from the Cytopro Rotor Maintenance Kit (SS-060) after autoclaving or if it is difficult to manipulate as follows:
  - 1 Turn the lid upside down.
  
  - 2 Place a small amount of grease directly into the lid locking pin receptacle.
  
  - 3 Work the locking pin back and forth a number of times to allow grease to penetrate the mechanism.
  
  - 4 Check for and wipe off any excess grease at the mouth of the lid locking pin hole.

***Figure 9: Lubricating the Carousel Locking Pin***

SS-060 Grease

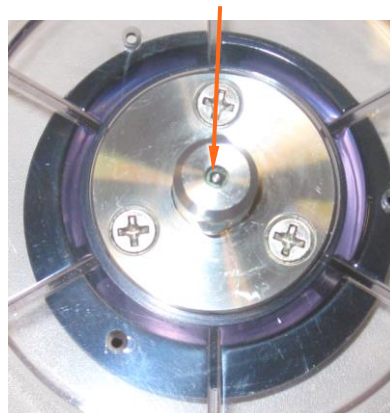



## SECTION 4 PREVENTIVE MAINTENANCE AND SAFETY

### ***4.1 Routine and Preventive Maintenance***

#### **Replacing Fuses**

**WARNING!**

**To prevent the risk of fire, the main fuses should only be replaced with fuses of the same type and rating. Recurring fuse failure indicates serious internal problems, if this occurs, contact Elitech Group.**

- 1 Power **OFF** the instrument.
- 2 Disconnect the power cord from the power outlet and the rear panel of the instrument.
- 3 Open the fuse cover by inserting a screwdriver in the slot on the right side of the cover and gently prying the cover out.
- 4 Pull the fuse holder out to inspect the fuses.
- 5 Replace the fuses if necessary.
- 6 Push the fuse holder in.
- 7 Close the fuse cover.
- 8 Reconnect the main power cord to rear panel of the instrument and to the power outlet.
- 9 Power **ON** the instrument.

## PREVENTIVE MAINTENANCE AND SAFETY

**4.2 Cleaning and Decontamination Procedures**

The rotor and chambers are designed to reduce the risk of fluid escaping into the rotor interior during cyto centrifugation. However, the chambers do not fully eliminate biohazard contamination risks. Introducing samples into the chambers, insecurely placed caps, improper placement of chambers, and/or exceeding the maximum volume can lead to contamination of the rotor interior.

The rotor seal is designed to prevent any fluid that may have contaminated the rotor interior from escaping into the environment. Check the rotor seals routinely for obvious cracks and tears. The rotor should be sterilized periodically, and whenever you observe or suspect a spill.

The nature of samples being run in the rotor should be considered when determining the frequency of rotor sterilization. In case of biohazard contamination, the user is responsible for performing all appropriate decontamination procedures.

**CAUTION:**

Never use acetone or other ketones, benzene, toluene, or other solvents to clean the instrument or rotor. Serious damage can result from using these substances.

**CAUTION:**

Contact Elitech Group before using any decontamination methods or cleaning agents other than those shown in this manual. Other methods can damage the rotor or instrument and void the warranty.

**WARNING!**

**The rotor should always be opened and closed in a biological safety hood. Always wear proper eye and hand protection when handling samples and unloading the chambers from the rotor.**

**NOTE:** *Sample spillage may be caused by cyto centrifugation without chamber caps in place and/or by over-filling the chamber. Pad leakage in standard volume chambers may be caused by running large sample volumes or alcoholic solutions at high rotor speeds. To avoid such problems, follow the recommendations in Table 3: Sample Treatment Options (Section 1.1). For further information contact Elitech Group.*

## SECTION 4 PREVENTIVE MAINTENANCE AND SAFETY

### **4.2 Cleaning and Decontamination Procedures**

#### **Cleaning the Case Exterior and Lid**

Cleaning these surfaces requires care to avoid damage. Never use abrasive powdered cleaners, or solvents as described previously.

#### **WARNING!**

**Disconnect the instrument from line power before cleaning with liquids.**

- 1 Wipe surfaces with warm soapy water. Further sterilization can be done with household bleach or a 2 percent glutaraldehyde solution.

#### **CAUTION:**

Do not pour or spill liquid into the instrument bowl. If liquid spills over the drive hub base, it can cause serious damage to the drive motor or electronics.

#### **Cleaning the Instrument Bowl and Inner Lid**

If you observe or suspect that sample fluid has contacted any of these surfaces:

- 1 Wipe the surface clean using soap and warm water.
- 2 Disinfect as required for the particular substance. See further information in this section.
- 3 Remove all moisture from the instrument bowl.

#### **Chemically Disinfecting the Rotor**

To chemically disinfect for Human Immunodeficiency Virus (HIV) or Mycobacterium tuberculosis:

- 1 Spray with diluted (1/256 x 30 mL/gallon of water) Vesphene II SE\* or some other intermediate level disinfecting detergent and soak for at least 20 minutes.
- 2 Remove detergent by thoroughly rinsing with tap water.
- 3 If sporicidal sterilization is required, follow the above disinfectant with 2% alkaline activated glutaraldehyde for 10 hours.
- 4 Completely remove all chemical solutions with water before reusing the rotor.
- 5 Wipe the rotor dry.

\* Vesphene II SE is a product of STERIS Corporation.

**NOTE:** *This procedure is not considered effective against Creutzfeldt-Jakob Disease virus (CJD).*

SECTION 4  
PREVENTIVE MAINTENANCE AND SAFETY

**4.2 Cleaning and Decontamination Procedures**

**Autoclaving the Rotor**

- 1 Autoclave the rotor for 60 minutes at 132 °C.

*Note: Open the lid to allow steam penetration inside the rotor.*

**WARNING!**

All rotor seals can be sterilized with the rotor, either chemically or by autoclaving. Frequent autoclaving may decrease the useful life of the seals. All seals will eventually show signs of wear, such as discoloration, dryness (or brittleness), cracks, or stretching. Replace seals yearly, or whenever they show any signs of wear.

This procedure sterilizes the rotor, inactivating even highly resistant agents such as the Creutzfeldt-Jakob Disease virus (CJD).

**WARNING!**

These decontamination procedures are for routine use only. For shipping the rotor or components to Elitech Group for repair or service, contact Elitech Group service or your local distributor for a current copy of the decontamination and shipping instructions before preparing and shipping the instrument. Shipping the rotor or components without decontaminating them according to these instructions will result in a significant decontamination charge and is dangerous to service personnel. If you intend to ship the rotor to another location or to discard it you must refer to Section 4.3.

## SECTION 4 PREVENTIVE MAINTENANCE AND SAFETY

### **4.2 Cleaning and Decontamination Procedures**

#### **Chemically Disinfecting Single or Dual Chambers**

- 1 Remove used Cytopads as described in Section 3.1.
- 2 Submerge chambers and frames in diluted (1/10) household bleach. Make dilution fresh each day.
- 3 Soak for at least one hour.
- 4 Scrub interior chamber surfaces with detergent-soaked cotton-tipped swab to remove residual cells.

**Note:** *This procedure is effective against Hepatitis B (HBV) and HIV and is at least partially effective against CJD. Treatment with sodium hypochlorite followed by 1N sodium hydroxide for 1 hour is considered completely effective against CJD.*

#### **CAUTION!**

**Using sodium hydroxide on the rotor can cause serious damage.**

- 5 Rinse thoroughly with deionized water and dry before reuse.

#### **Autoclaving Single or Dual Chambers**

- 1 Submerge the frame and chamber in any dilute detergent solution.
- 2 Remove frame and chamber from the detergent solution.
- 3 Autoclave for at least one hour at 132 °C for complete sterilization and certain inactivation of CJD virus.

**Note:** *While the Cytopro single or dual chambers are reusable, autoclaving limits chamber life. Discard any chamber, frame, or cap that appears distorted or will not fit with other components. Most chambers can be autoclaved up to 20 times without showing any signs of degradation. CYTOPRO MAGNUM CHAMBERS ARE NOT REUSABLE. DO NOT ATTEMPT TO CLEAN OR REUSE.*

SECTION 4  
PREVENTIVE MAINTENANCE AND SAFETY

**4.3 Shipping or Disposing of the Instrument and Rotor**

**Shipping the Instrument or Rotor**

**WARNING!**

You must disinfect the instrument or rotor before returning it to Elitech Group. The operating authority must complete a Hazard Free Certification Form (see below), otherwise the distributor or service center may not accept the instrument; or customs authorities may hold it.

**CAUTION:**

Shipping the instrument or rotor without decontaminating it according to these instructions is dangerous to service personnel. You will be charged additional fees for decontamination performed by Elitech Group.

**CAUTION:**

Ship the instrument in a container comparable to its original packaging.

**Hazard Free Certification Form**

The operating authority must print and complete the Hazard Free Certification Form (DOC4-00034) obtained from Customer Service.

Attach the declaration to the top of the instrument package before sending the package to Elitech Group.

**Disposing of the Instrument or Rotor**

The instrument or rotor should be completely decontaminated and disposed of as follows:



Under WEEE Directive 2002/96/EC, this equipment cannot be disposed of in a normal landfill. Instead, the equipment must be disposed of either by:

- 1 Routing to an authorized local facility approved for handling hazardous materials.

OR

- 2 Returning the equipment to Elitech Group.

## SECTION 5 SOLVING PROBLEMS

### 5.1 Troubleshooting

This section helps you identify and solve routine problems with the Cytopro. More difficult problems may require technical service. Contact your Elitech Group representative for assistance.



**WARNING!**

**Due to the electrical shock hazard, do not open this instrument or attempt internal repairs. Refer servicing to qualified service personnel. Contact your dealer or Elitech Group Service.**

**Table 7: General Troubleshooting and Diagnosis**

Problem	Solution
There is no power to the instrument when the power switch is turned ON.	Check the facility outlet and the power cord connection. Check the fuses. Refer to the Replacing Fuses procedure. <b>CAUTION:</b> Fuse failure may indicate a serious internal problem.
Strange information shows on the display, and/or erratic instrument operation.	Switch the instrument <b>OFF</b> , wait 10 to 20 seconds, then switch power <b>ON</b> again. If problem recurs, install a computer-type surge suppressor to protect the instrument from power line transients. If possible, connect the instrument to a power circuit that is not shared by centrifuges, refrigerators, air conditioners, or other motorized equipment.  If the above steps do not solve the problem, consult the Service Manual, or contact your dealer or Elitech Group for assistance.
Electronic Failure	An electronic failure would appear as an obvious malfunction such as a scrambled or totally inoperative display panel.  Transient voltages coming through the power lines may cause the device to "lose its place."  1 If this occurs, switch the main power <b>OFF</b> for 10-20 seconds and then back <b>ON</b> to reset the instrument.  2 If the problem recurs, install a computer-type surge protector to isolate the instrument.  3 If possible, connect the device to a power circuit not shared by centrifuges, refrigerators, air conditioners, or other motorized equipment.  If the problem recurs, contact your dealer or Elitech Group for assistance.

SECTION 5  
SOLVING PROBLEMS

**5.1 Troubleshooting**

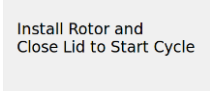
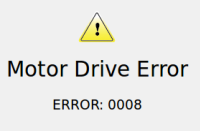
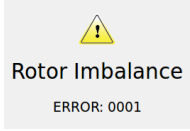
Problem	Solution
<p>Error messages on the screen.</p> <div style="text-align: center; margin: 20px 0;">  </div> <div style="text-align: center; margin: 20px 0;">  </div> <div style="text-align: center; margin: 20px 0;">  </div>	<p>If the display shows Lid Not Shut: Verify that the lid is fully closed and latched. If the Lid Not Shut indication remains, contact Elitech Group for assistance.</p> <p>If the display shows Wrong Rotor after pressing Start: Make sure the rotor is properly loaded on the drive hub. After verifying the rotor is correctly loaded, press <b>Start</b>. If the display still shows Wrong Rotor, there may be an internal problem.</p> <p>The microprocessor monitors rotor rotation during a cyto centrifuge cycle. The display shows an error message if the rotation is not within the specified range.</p> <p>If the display shows Motor Drive Error: Check the bowl for interference: Turn the hub or rotor by hand; it should turn freely.</p> <p>Drive motor or electronic component malfunctions require servicing of internal components. Contact your dealer or Elitech Group for assistance.</p> <p>If the display shows Rotor Imbalance, make certain the Cytopro rotor is balanced, and seated correctly on the hub.</p>



## SECTION 5 SOLVING PROBLEMS

### ***5.2 Calibrating the Touchscreen***

- 1 Press and hold **Standby/Ready** for 5 seconds. A calibration screen with a target appears.
- 2 Press the center of the target with a finger, stylus, or similar tool. Another target will appear in a different location.
- 3 Continue to press the center of the targets until you have pressed all the targets (five total). After the fifth target is pressed, the instrument will save the touch screen calibration and return to the Main menu.

## SECTION 6 CUSTOMER SERVICE

Elitech Group's Service Department will help you resolve any questions about the operation or performance of your Cytopro Cyto centrifuge.

Customers in the United States should contact us by telephone. Outside the U.S., our authorized dealers offer full local service and support.



**ELITechGroup Inc.**

370 West 1700 South  
Logan, Utah 84321-8212 USA

**Telephone:**

800 453 2725 (*United States & Canada*)  
(+1) 435 752 6011 (*International calls*)

**Fax:**

(+1) 435 752 4127

**Email:**

wescor.service@elitechgroup.com (*Service*)  
wescor.sales@elitechgroup.com (*Sales*)

**Web Page:**

[www.elitechgroup.com](http://www.elitechgroup.com)



**European Authorized Representative:**

Medical Technology Promedt Consulting  
Altenhofstr. 80  
D-66386 St. Ingbert  
Germany

Telephone: +49(0)68 94-58 10 20

Fax: +49(0)68 94-58 10 21

Email: [info@mt-procons.com](mailto:info@mt-procons.com)

APPENDIX

A

***Critical Reagent Components***



The following information is to identify the critical chemicals of each reagent used in this instrument.

SS-133 Decontamination Solution Concentrate contains:

<30% Germicidal Detergent

>70% Deionized Water

SS-133 Decontamination Solution Concentrate is associated with the following Risk and Safety Phrases.

European Symbol of Danger is Xi.

R 36/38	Irritating to eyes and skin.
S 60	This material and its container must be disposed of as hazardous waste.

**Accessories and Supplies**

Only replacement parts supplied by Elitech Group should be used with the Cyopro Cyto centrifuge. Use of non-approved parts may affect the performance and safety features of this product.

<b>ACCESSORIES</b>	<b>REFERENCE NUMBER</b>
Cyopro Cyto centrifuge Rotor .....	AC-160

<b>SUPPLIES</b>	<b>REFERENCE NUMBER</b>
Cyopro Rotor Maintenance Kit.....	SS-060
Chamber Caps (package of 48).....	SS-110
Fast (White) Cytopad Absorption Pads (box of 100) .....	SS-111
Slow (Tan) Cytopad Absorption Pads (box of 100) .....	SS-112
Sample Chambers with Fast (White) Cytopads and Caps (box of 48) .....	SS-113
Sample Chambers with Slow (Tan) Cytopads and Caps (box of 48) .....	SS-114
Sample Chambers with Fast (White) Cytopads (box of 48) .....	SS-115
Sample Chambers with Slow (Tan) Cytopads (box of 48).....	SS-116
Uncoated Custom Microscope slides for Cyopro (box of 1/2 gross).....	SS-117
Poly-L-Lysine Coated Custom Microscope Slides for Cyopro (box of 1/2 gross).....	SS-118
Decontamination Solution Concentrate (3.75 mL vial dilutes to 244 mL) .....	SS-133
Dual Sample Chamber Caps (package of 48) .....	SS-210
Fast (White) Cytopad Dual Sample Absorption Pads (package of 100).....	SS-211
Slow (Tan) Cytopad Dual Sample Absorption Pads (package of 100).....	SS-212
Dual Sample Chambers with Caps and Fast (White) Cytopads (package of 48) .....	SS-213
Dual Sample Chambers with Caps and Slow (Tan) Cytopads (package of 48).....	SS-214
Dual Sample Chambers with Fast (White) Cytopads (package of 48) .....	SS-215
Dual Sample Chambers with Slow (Tan) Cytopads (package of 48) .....	SS-216
Uncoated Custom Microscope Slides for Cyopro Dual Sample Chambers (box of 1/2 gross) .....	SS-217
Poly-L-Lysine Coated Custom Microscope Slides for Cyopro Dual Sample Chambers (box of 1/2 gross) .....	SS-218
Uncoated Custom Microscope Slides for Cyopro Magnum Sample Chambers (box of 1/2 gross) .....	SS-232
Poly-L-Lysine Coated Custom Microscope Slides for Cyopro Magnum Sample Chamber (box of 1/2 gross) .....	SS-233
Cyopro Magnum Chambers with Caps (box of 24) .....	SS-234

<b>REPLACEMENT PARTS FOR AC-160 ROTOR</b>	<b>REFERENCE NUMBER</b>
Lid Knob Assembly.....	RP-267
Ball Housing Assembly.....	RP-265
Hub Seal.....	RP-268
Bowl Seal .....	RP-269
Rotor Lid Assembly .....	RP-221
Cyopro (Model 7622) Applications Manual .....	RP-463
Cyopro Methods Manual .....	RP-451

Contact Elitech Group for a complete list of replacement parts.

ELITechGroup Inc.  
370 West 1700 South  
Logan, Utah 84321-8212  
USA  
800 453 2725  
+1 435 752 6011

[WWW.ELITECHGROUP.COM](http://WWW.ELITECHGROUP.COM)